

**Performance Curve**

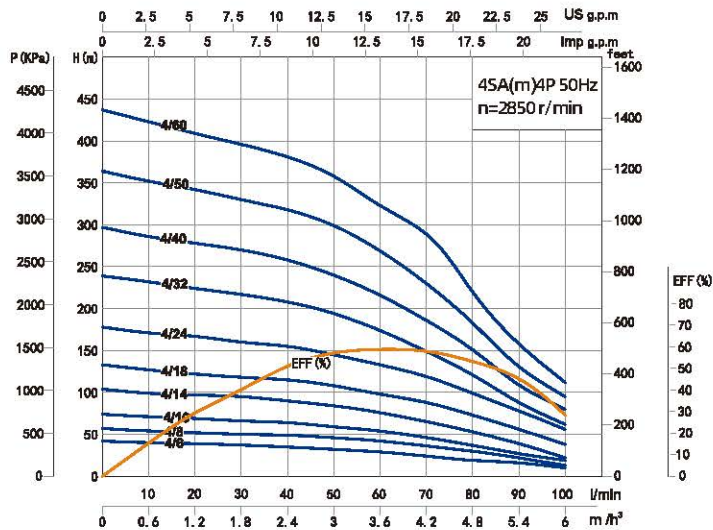

Performance Curve

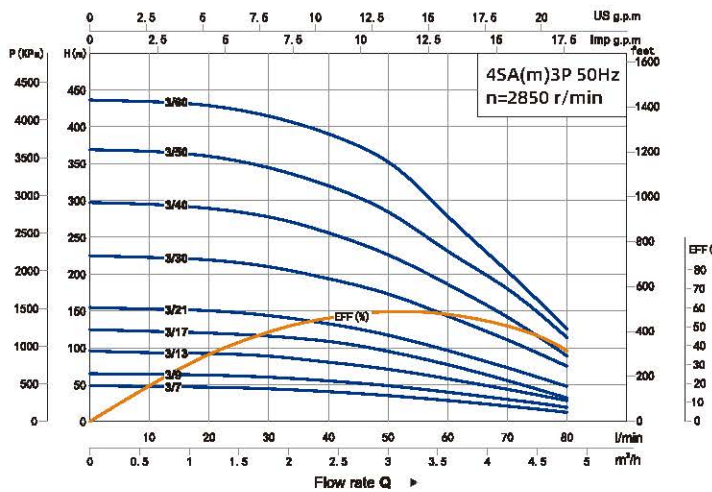
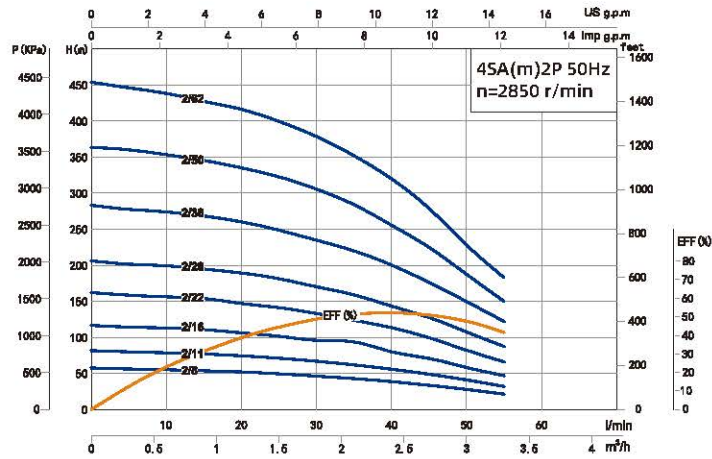
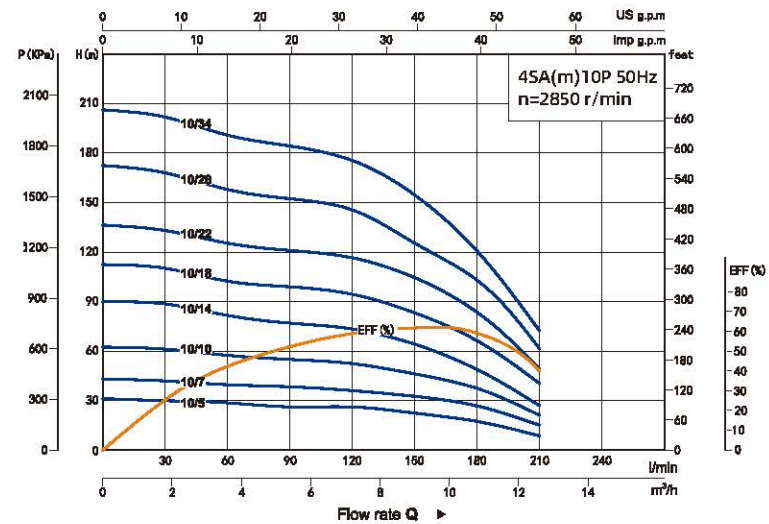
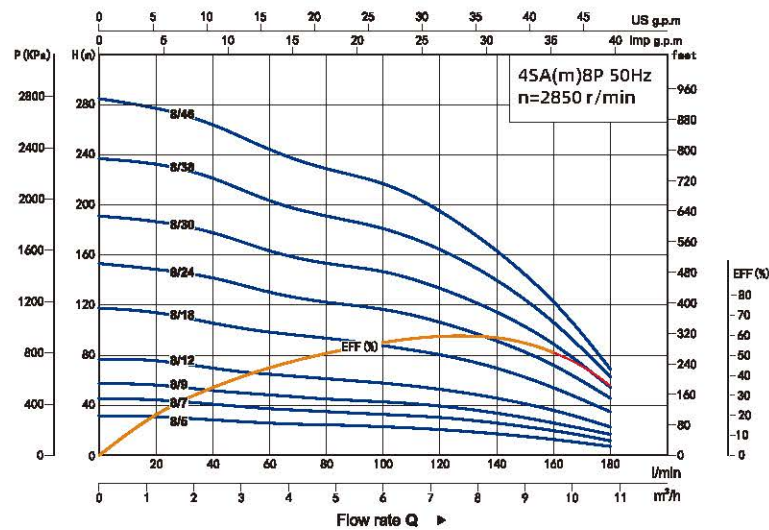
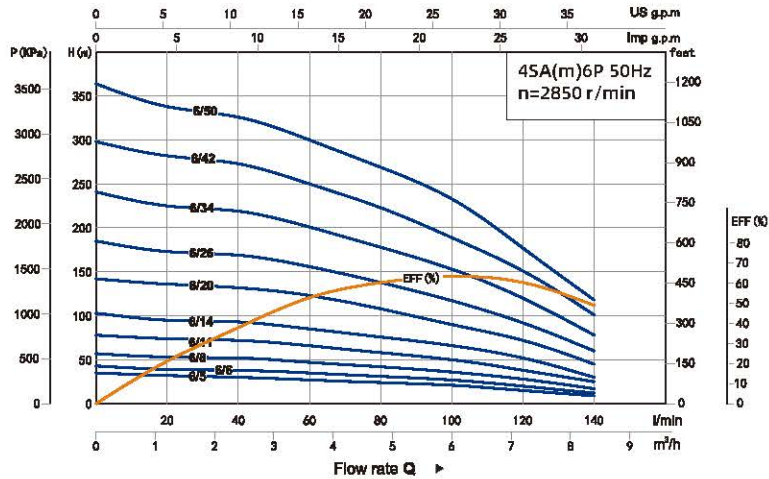

**Performance Curve**

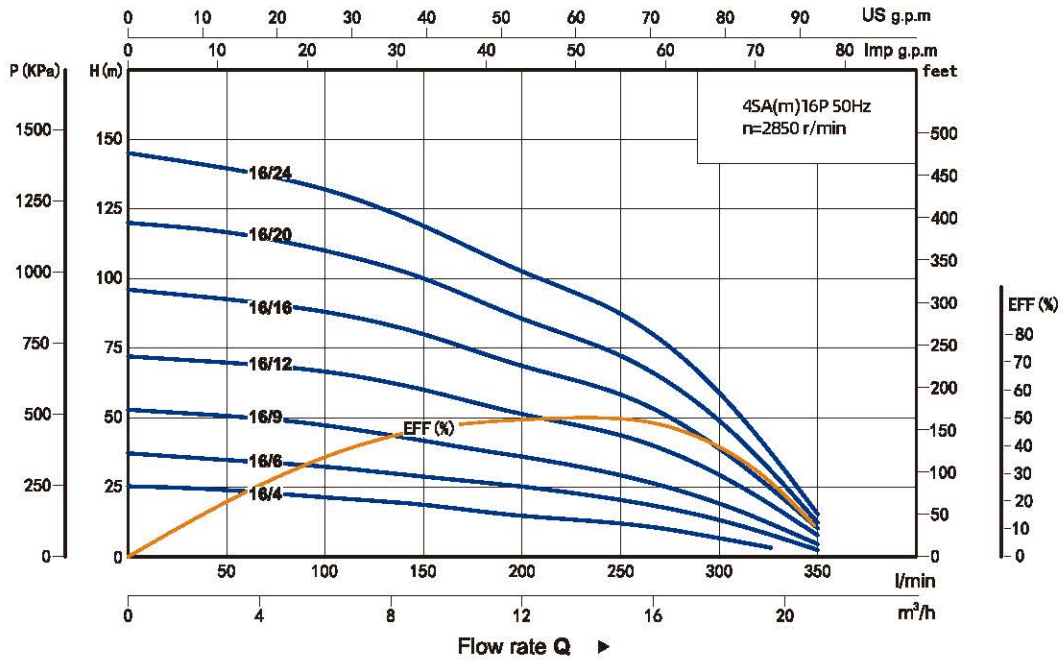
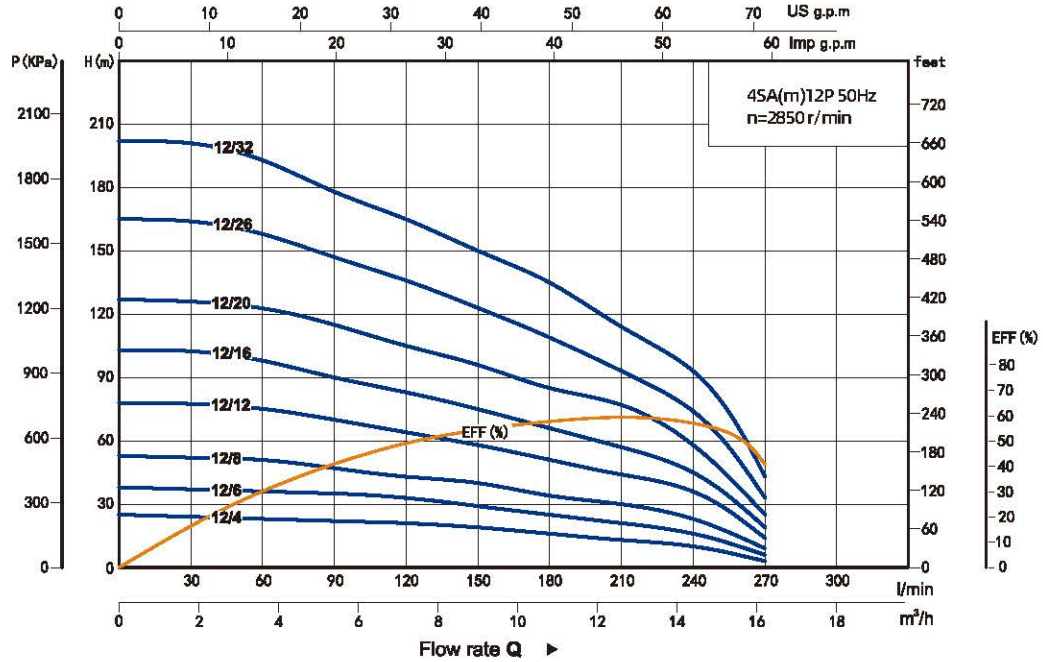



Model		Power		Rate Current (A)		Flow														Head Range (m)
Single-Phase	Three-Phase	kW	HP	Single-Phase	Three-Phase	m <sup>3</sup> /h	0	0.3	0.6	0.9	1.2	1.5	1.8	2.1	2.4	2.7	3	3.3		
220V	380V			220V	380V		l/min	0	5	10	15	20	25	30	35	40	45	50	55	
4SAm3/7-0.37P	-	0.37	0.5	4.2	-	H(m)	58	56	55	54	52	50	46	43	38	34	27	21	55~22	
4SAm3/9-0.55P	-	0.55	0.75	5.2	-		80	80	79	77	74	71	67	62	56	49	41	32	77~34	
4SAm3/13-0.75P	4SA2/16-0.75P	0.75	1	6.9	2.7		117	114	113	111	106	102	96	94	80	71	58	47	113~49	
4SAm3/17-1.1P	4SA2/22-1.1P	1.1	1.5	9.5	3.6		162	159	156	154	147	141	133	124	113	100	82	66	156~69	
4SAm3/21-1.5P	4SA2/28-1.5P	1.5	2	12.2	4.8		206	202	199	195	189	181	170	159	143	128	108	87	199~91	
4SAm3/30-2.2P	4SA2/38-2.2P	2.2	3	17.3	6.4		283	278	274	268	260	249	235	220	200	176	150	122	274~127	
-	4SA2/50-3P	3	4	-	8.9		364	360	353	345	335	323	306	284	256	225	188	150	353~156	
-	4SA2/62-4P	4	5.5	-	10.9		454	446	438	427	416	400	379	352	320	279	228	183	438~190	

Model		Power		Rate Current (A)		Flow										Head Range (m)
Single-Phase	Three-Phase	kW	HP	Single-Phase	Three-Phase	m <sup>3</sup> /h	0	0.6	1.2	1.8	2.4	3	3.6	4.2	4.8	
220V	380V			220V	380V		l/min	0	10	20	30	40	50	60	70	
4SAm3/7-0.37P	-	0.37	0.5	4.2	-	H(m)	49	48	47	44	40	35	28	23	12	47~25
4SAm3/9-0.55P	-	0.55	0.75	5.2	-		65	64	63	60	55	48	40	30	19	63~35
4SAm3/13-0.75P	4SA3/13-0.75P	0.75	1	6.9	2.7		96	93	92	89	80	71	58	44	28	92~51
4SAm3/17-1.1P	4SA3/17-1.1P	1.1	1.5	9.5	3.6		125	122	120	116	109	95	77	56	32	120~67
4SAm3/21-1.5P	4SA3/21-1.5P	1.5	2	12.2	4.8		155	153	150	144	133	117	96	73	48	150~85
4SAm3/30-2.2P	4SA3/30-2.2P	2.2	3	17.3	6.4		225	223	219	210	194	173	143	111	75	219~127
-	4SA3/40-3P	3	4	-	8.9		297	295	289	278	256	226	186	142	89	289~165
-	4SA3/50-4P	4	5.5	-	10.9		369	367	360	344	320	284	231	180	114	360~206
-	4SA3/60-5.5P	5.5	7.5	-	15.4	436	434	429	415	387	352	273	204	125	429~241	

Model		Power		Rate Current (A)		Flow												Head Range (m)
Single-Phase	Three-Phase	kW	HP	Single-Phase	Three-Phase	m <sup>3</sup> /h	0	0.6	1.2	1.8	2.4	3	3.6	4.2	4.8	5.4	6	
220V	380V			220V	380V		l/min	0	10	20	30	40	50	60	70	80	90	
4SAm4/6-0.37P	-	0.37	0.5	4.2	-	H(m)	42	40	39	37	35	32	29	24	19	16	10	39~15
4SAm4/8-0.55P	-	0.55	0.75	5.2	-		57	54	52	50	49	46	44	36	30	22	13	52~21
4SAm4/10-0.75P	4SA4/10-0.75P	0.75	1	6.9	2.7		74	71	69	66	64	59	54	46	37	27	19	69~30
4SAm4/14-1.1P	4SA4/14-1.1P	1.1	1.5	9.5	3.6		104	99	97	95	90	84	76	65	53	39	22	97~43
4SAm4/18-1.5P	4SA4/18-1.5P	1.5	2	12.2	4.8		133	127	122	118	115	108	98	88	73	56	38	124~57
4SAm4/24-2.2P	4SA4/24-2.2P	2.2	3	17.3	6.4		178	171	167	160	155	145	133	119	99	78	56	167~79
-	4SA4/32-3P	3	4	-	8.9		239	232	224	217	208	194	174	149	121	88	62	210~100
-	4SA4/40-4P	4	5.5	-	10.9		297	286	278	270	258	240	216	186	151	109	80	266~110
-	4SA4/50-5.5P	5.5	7.5	-	15.4	364	352	342	330	318	299	269	230	183	131	95	336~177	
-	4SA4/60-7.5P	7.5	10	-	18.6	437	423	409	396	381	358	323	289	220	158	112	404~210	

Model		Power		Rate Current (A)		Flow								Head Range (m)	
Single-Phase	Three-Phase	kW	HP	Single-Phase	Three-Phase	m <sup>3</sup> /h	0	1.2	2.4	3.6	4.8	6	7.2		8.4
220V	380V			220V	380V		l/min	0	20	40	60	80	100		120
4SAm6/5-0.37P	-	0.37	0.55	4.2	-	H(m)	35	32	30	27	24	21	15	9	30~11
4SAm6/6-0.55P	-	0.55	0.75	5.2	-		43	39	38	35	31	27	20	12	38~16
4SAm6/8-0.75P	4SA6/8-0.75P	0.75	1	6.9	2.7		57	53	52	47	42	36	28	17	52~22
4SAm6/11-1.1P	4SA6/11-1.1P	1.1	1.5	9.5	3.6		78	74	72	66	58	50	38	25	73~31
4SAm6/14-1.5P	4SA6/14-1.5P	1.5	2	12.2	4.8		103	95	93	85	76	66	52	30	93~40
4SAm6/20-2.2P	4SA6/20-2.2P	2.2	3	17.3	6.4		142	136	132	123	108	90	72	45	135~55
-	4SA6/26-3P	3	4	-	8.9		185	173	169	156	138	117	92	60	172~75
-	4SA6/34-4P	4	5.5	-	10.9		241	225	219	201	178	153	120	78	223~98
-	4SA6/42-5.5P	5.5	7.5	-	15.4	298	282	273	250	223	189	151	101	278~130	
-	4SA6/50-7.5P	7.5	10	-	18.6	364	338	326	300	269	233	177	118	334~148	

Model		Power		Rate Current (A)		Flow											Head Range (m)
Single-Phase	Three-Phase	kW	HP	Single-Phase	Three-Phase	m <sup>3</sup> /h	0	1.2	2.4	3.6	4.8	6	7.2	8.4	9.6	10.8	
220V	380V			220V	380V	l/min	0	20	40	60	80	100	120	140	160	180	
4SAm8/5-0.55P	-	0.55	0.75	5.2	-	H(m)	32	31	28	26	25	23	21	17	13	7	28~11
4SAm8/7-0.75P	4SA8/7-0.75P	0.75	1	6.9	2.7		46	44	41	37	35	33	30	26	20	12	41~17
4SAm8/9-1.1P	4SA8/9-1.1P	1.1	1.5	9.5	3.6		57	56	52	48	45	43	39	34	28	17	52~23
4SAm8/12-1.5P	4SA8/12-1.5P	1.5	2	12.2	4.8		77	76	70	65	61	58	53	46	36	23	70~32
4SAm8/18-2.2P	4SA8/18-2.2P	2.2	3	17.3	6.4		118	114	106	98	94	88	80	70	54	35	106~48
-	4SA8/24-3P	3	4	-	8.9		153	149	142	130	122	117	106	91	72	46	142~64
-	4SA8/30-4P	4	5.5	-	10.9		191	187	178	163	153	147	133	114	89	54	178~78
-	4SA8/38-5.5P	5.5	7.5	-	15.4		237	232	221	203	191	181	164	140	106	62	221~93
-	4SA8/46-7.5P	7.5	10	-	18.6		285	277	264	244	229	217	195	163	123	69	264~106

Model		Power		Rate Current (A)		Flow										Head Range (m)
Single-Phase	Three-Phase	kW	HP	Single-Phase	Three-Phase	m <sup>3</sup> /h	0	1.8	3.6	5.4	7.2	9	10.8	12.6		
220V	380V			220V	380V	l/min	0	30	60	90	120	150	180	210		
4SAm10/5-0.75P	4SA10/5-0.75P	0.75	1	6.9	2.7	H(m)	31	30	29	27	26	23	18	9	29~9	
4SAm10/7-1.1P	4SA10/7-1.1P	1.1	1.5	9.5	3.6		43	42	40	39	36	33	27	15	40~15	
4SAm10/10-1.5P	4SA10/10-1.5P	1.5	2	12.2	4.8		63	61	58	55	53	46	38	21	59~21	
4SAm10/14-2.2P	4SA10/14-2.2P	2.2	3	17.3	6.4		90	89	82	77	74	64	49	26	84~26	
-	4SA10/18-3P	3	4	-	8.9		113	110	102	99	95	83	66	41	105~41	
-	4SA10/22-4P	4	5.5	-	10.9		136	133	125	121	117	105	84	50	128~50	
-	4SA10/28-5.5P	5.5	7.5	-	15.4		172	168	158	152	146	125	103	62	161~62	
-	4SA10/34-7.5P	7.5	10	-	18.6		206	202	191	184	175	155	121	72	194~72	

Model		Power		Rate Current (A)		Flow											Head Range (m)
Single-Phase	Three-Phase	kW	HP	Single-Phase	Three-Phase	m <sup>3</sup> /h	0	1.8	3.6	5.4	7.2	9	10.8	12.6	14.4	16.2	
220V	380V			220V	380V	l/min	0	30	60	90	120	150	180	210	240	270	
4SAm12/4-0.75P	4SA12/4-0.75P	0.75	1	6.9	2.7	H(m)	25	24	23	22	21	19	16	13	10	3	23~9
4SAm12/6-1.1P	4SA12/6-1.1P	1.1	1.5	9.5	3.6		38	37	36	35	33	29	25	21	16	6	35~16
4SAm12/8-1.5P	4SA12/8-1.5P	1.5	2	12.2	4.8		53	52	51	47	43	40	34	30	23	9	49~21
4SAm12/12-2.2P	4SA12/12-2.2P	2.2	3	17.3	6.4		78	77	76	70	64	58	51	44	36	14	73~35
-	4SA12/16-3P	3	4	-	8.9		103	102	98	90	83	75	66	57	45	19	95~45
-	4SA12/20-4P	4	5.5	-	10.9		127	126	124	115	105	96	85	77	58	25	119~56
-	4SA12/26-5.5P	5.5	7.5	-	15.4		165	164	158	147	136	123	109	93	74	33	152~69
-	4SA12/32-7.5P	7.5	10	-	18.6		202	201	193	178	165	150	135	114	93	43	189~88

Model		Power		Rate Current (A)		Flow											Head Range (m)
Single-Phase	Three-Phase	kW	HP	Single-Phase	Three-Phase	m <sup>3</sup> /h	0	3	6	9	12	15	18	21			
220V	380V			220V	380V	l/min	0	50	100	150	200	250	300	350			
4SAm16/4-1.1P	4SA16/4-1.1P	1.1	1.5	9.5	3.6	H(m)	25	24	21	19	15	12	7	-	23~3		
4SAm16/6-1.5P	4SA16/6-1.5P	1.5	2	12.2	4.8		37	35	32	29	25	20	13	3	34~8		
4SAm16/9-2.2P	4SA16/9-2.2P	2.2	3	17.3	6.4		53	51	47	42	36	29	19	5	49~13		
-	4SA16/12-3P	3	4	-	8.9		72	70	67	60	51	44	29	8	68~19		
-	4SA16/16-4P	4	5.5	-	10.9		96	93	88	80	69	58	39	10	91~25		
-	4SA16/20-5.5P	5.5	7.5	-	15.4		120	117	110	100	86	72	49	12	114~32		
-	4SA16/24-7.5P	7.5	10	-	18.6		145	140	132	119	103	87	59	15	136~38		



## Components & Materials

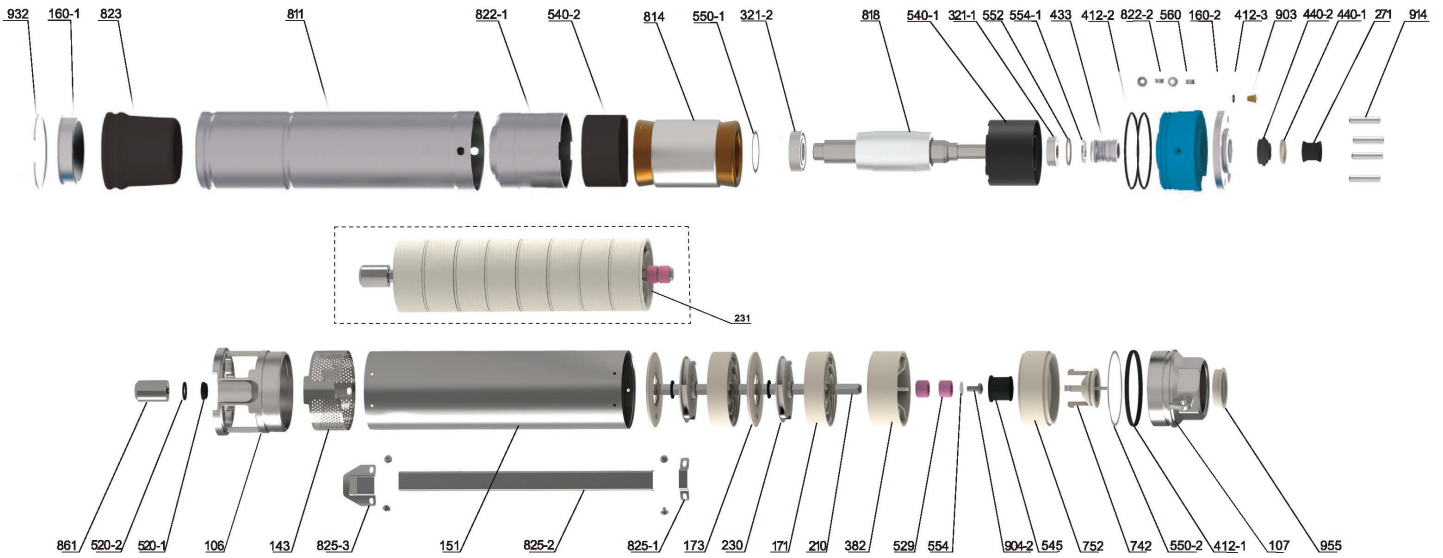

No.	Part name	No.	Part name	No.	Part name
106	Inlet joint	412-2	O-ring	742	Bonnet
107	Delivery chamber	412-3	O-ring	811	Casing
143	Net cover	433	Mechanical seal	814	Stator core with winding
151	Sleeve	440-1	Anti-sand pad	818	Rotor
160-1	Bottom cover	440-2	Anti-sand seat	822-1	Lower bearing block
160-2	Cover plate	520-1	Spacer bush	822-2	Oil chamber
171	Guide vane	520-2	Spacer bush	823	Pressure regulating film
173	Guide vane cover plate	529	Shaft sleeve	825-1	Small pressing plate
210	Pump shaft	540-1	Upper spacer sleeve	825-2	Cable pressing plate
230	Impeller	540-2	Lower spacer sleeve	861	Coupling
231	Impeller string	545	Middle rubber bearing	903	Vent cock
271	Sand shaking sleeve	550-1	Adjusting washer	914	Hexagon socket set screw
321-1	Deep groove ball bearing	550-2	Adjusting washer	932	Retaining ring
321-2	Angular contact bearing	552	Wave spring	955	Dust cover
382	Middle bearing block	554	Flat washer		
412-1	O-ring	560	Locating pin		

## Dimensions & Weight

Model		Pipe Connection (DN)	Dim. (mm)			N.W. (kg)		
Single-phase	Three-phase		B	A Single-Phase	Three-phase	Body(kg)	Motor(kg)	
							Single-phase	Three-phase
4SAm2/8-0.37P	-	G1¼	395	696	-	3	7.4	-
4SAm2/11-0.55P	-		469	790	-	3.6	8.3	-
4SAm2/16-0.75P	4SA2/16-0.75P		594	940	930	4.5	9.4	8.4
4SAm2/22-1.1P	4SA2/22-1.1P		778	1159	1149	5.8	11.1	10
4SAm2/28-1.5P	4SA2/28-1.5P		962	1388	1343	7.3	13.1	10.6
4SAm2/38-2.2P	4SA2/38-2.2P		1210	1696	1646	9.8	15.8	13
-	4SA2/50-3P		1544	-	2057	12.9	-	17.5
-	4SA2/62-4P		1877	-	2460	16	-	20.5

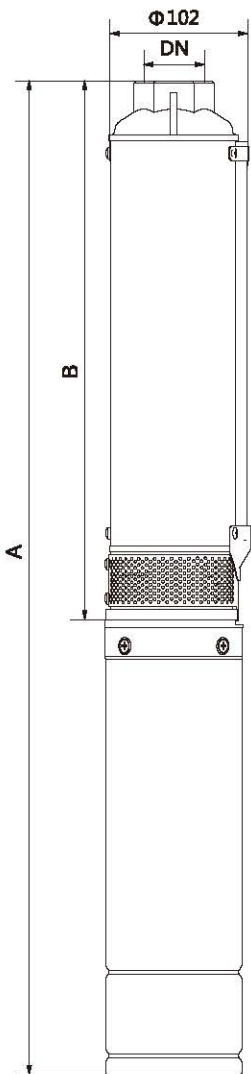

Model		Pipe Connection (DN)	Dim. (mm)			N.W. (kg)		
Single-phase	Three-phase		B	A Single-Phase	Three-phase	Body(kg)	Motor(kg)	
							Single-phase	Three-phase
4SAm3/7-0.37P	-	G1¼	379	680	-	2.6	7.4	-
4SAm3/9-0.55P	-		431	752	-	3.1	8.3	-
4SAm3/13-0.75P	4SA3/13-0.75P		535	881	871	4.2	9.4	8.4
4SAm3/17-1.1P	4SA3/17-1.1P		639	1020	1010	4.8	11.1	10
4SAm3/21-1.5P	4SA3/21-1.5P		813	1239	1194	6	13.1	10.6
4SAm3/30-2.2P	4SA3/30-2.2P		1048	1534	1484	7.8	15.8	13
-	4SA3/40-3P		1343	-	1856	10.6	-	17.5
-	4SA3/50-4P		1604	-	2187	13.5	-	20.5
-	4SA3/60-5.5P		1899	-	2552	16	-	24

Model		Pipe Connection (DN)	Dim. (mm)			N.W. (kg)		
Single-phase	Three-phase		B	A Single-Phase	Three-phase	Body(kg)	Motor(kg)	
							Single-phase	Three-phase
4SAm4/6-0.37P	-	G1¼	371	672	-	2.6	7.4	-
4SAm4/8-0.55P	-		429	750	-	3.0	8.3	-
4SAm4/10-0.75P	4SA4/10-0.75P		487	833	823	3.5	9.4	8.4
4SAm4/14-1.1P	4SA4/14-1.1P		603	984	974	4.2	11.1	10
4SAm4/18-1.5P	4SA4/18-1.5P		789	1215	1170	5.6	13.1	10.6
4SAm4/24-2.2P	4SA4/24-2.2P		963	1449	1399	6.7	15.8	13
-	4SA4/32-3P		1231	-	1744	8.7	-	17.5
-	4SA4/40-4P		1463	-	2046	11.0	-	20.5
-	4SA4/50-5.5P		1789	-	2442	13.9	-	24
-	4SA4/60-7.5P		2079	-	2872	16.3	-	30.5

Model		Pipe Connection (DN)	Dim. (mm)			N.W. (kg)		
Single-phase	Three-phase		B	A Single-Phase	Three-phase	Body(kg)	Motor(kg)	
							Single-phase	Three-phase
4SAm6/5-0.37P	-	G1½	361	662	-	2.6	7.4	-
4SAm6/6-0.55P	-		393	714	-	2.8	8.3	-
4SAm6/8-0.75P	4SA6/8-0.75P		459	805	795	3.3	9.4	8.4
4SAm6/11-1.1P	4SA6/11-1.1P		558	939	929	4.1	11.1	10
4SAm6/14-1.5P	4SA6/14-1.5P		692	1118	1073	4.9	13.1	10.6
4SAm6/20-2.2P	4SA6/20-2.2P		923	1409	1359	6.4	15.8	13
-	4SA6/26-3P		1120	-	1633	8.2	-	17.5
-	4SA6/34-4P		1416	-	1999	10.3	-	20.5
-	4SA6/42-5.5P		1679	-	2332	12.3	-	24
-	4SA6/50-7.5P		1978	-	2771	15.3	-	30.5

## Dimensions & Weight

Model		Pipe Connection (DN)	Dim. (mm)			N.W.(kg)		
Single-phase	Three-phase		B	A Single-Phase	Three-phase	Body(kg)	Motor(kg)	
							Single-phase	Three-phase
4SAm8/5-0.55P	-	G2	387	708	-	2.7	8.3	-
4SAm8/7-0.75P	4SA8/7-0.75P		463	809	799	3.2	9.4	8.4
4SAm8/9-1.1P	4SA8/9-1.1P		539	920	910	3.7	11.1	10
4SAm8/12-1.5P	4SA8/12-1.5P		688	1114	1069	4.7	13.1	10.6
4SAm8/18-2.2P	4SA8/18-2.2P		951	1437	1387	6.5	15.8	13
-	4SA8/24-3P		1179	-	1692	8.5	-	17.5
-	4SA8/30-4P		1443	-	2026	10	-	20.5
-	4SA8/38-5.5P		1782	-	2435	12.7	-	24
-	4SA8/46-7.5P		2086	-	2879	16	-	30.5

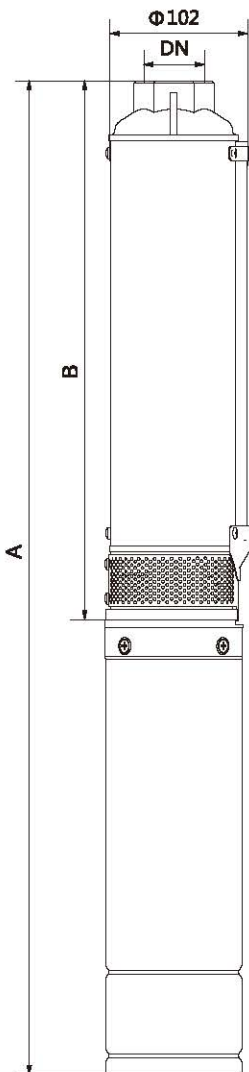

Model		Pipe Connection (DN)	Dim. (mm)			N.W.(kg)		
Single-phase	Three-phase		B	A Single-Phase	Three-phase	Body(kg)	Motor(kg)	
							Single-phase	Three-phase
4SAm10/5-0.75P	4SA10/5-0.75P	G2	387	733	723	2.7	9.4	8.4
4SAm10/7-1.1P	4SA10/7-1.1P		463	844	834	3.3	11.1	10
4SAm10/10-1.5P	4SA10/10-1.5P		612	1038	993	4.3	13.1	10.6
4SAm10/14-2.2P	4SA10/14-2.2P		799	1285	1235	5.4	15.8	13
-	4SA10/18-3P		951	-	1464	6.7	-	17.5
-	4SA10/22-4P		1103	-	1686	7.8	-	20.5
-	4SA10/28-5.5P		1366	-	2019	9.7	-	24
-	4SA10/34-7.5P		1595	-	2388	11.5	-	30.5

Model		Pipe Connection (DN)	Dim. (mm)			N.W.(kg)		
Single-phase	Three-phase		B	A Single-Phase	Three-phase	Body(kg)	Motor(kg)	
							Single-phase	Three-phase
4SAm12/4-0.75P	4SA12/4-0.75P	G2	447	793	783	3.3	9.4	8.4
4SAm12/6-1.1P	4SA12/6-1.1P		545	926	916	4.0	11.1	10
4SAm12/8-1.5P	4SA12/8-1.5P		642	1068	1023	4.8	13.1	10.6
4SAm12/12-2.2P	4SA12/12-2.2P		893	1379	1329	6.6	15.8	13
-	4SA12/16-3P		1087	-	1600	8.3	-	17.5
-	4SA12/20-4P		1338	-	1921	10.6	-	20.5
-	4SA12/26-5.5P		1630	-	2283	12.8	-	24
-	4SA12/32-7.5P		1976	-	2769	15.3	-	30.5

Model		Pipe Connection (DN)	Dim. (mm)			N.W.(kg)		
Single-phase	Three-phase		B	A Single-Phase	Three-phase	Body(kg)	Motor(kg)	
							Single-phase	Three-phase
4SAm16/4-1.1P	4SA16/4-1.1P	G2	551	932	922	4	11.1	10
4SAm16/6-1.5P	4SA16/6-1.5P		701	1127	1082	5.2	13.1	10.6
4SAm16/9-2.2P	4SA16/9-2.2P		928	1414	1364	6.7	15.8	13
-	4SA16/12-3P		1156	-	1669	8.2	-	17.5
-	4SA16/16-4P		1459	-	2042	11	-	20.5
-	4SA16/20-5.5P		1762	-	2415	13	-	24
-	4SA16/24-7.5P		2065	-	2858	15.6	-	30.5



## Packing Size & Weight

Model		Dim. (mm)					G.W.(kg)		20"Loading Qty.(pcs)	
Single-phase	Three-phase	Motor(LxWxH)		Body (LxWxH)	Pump(LxWxH)		Single-phase	Three-phase	Single-phase	Three-phase
		Single-phase	Three-phase		Single-phase	Three-phase				
4SAm2/8-0.37P	-	-	-	-	1020x110x185	-	11.2	-	1340	-
4SAm2/11-0.55P	-	-	-	-	1130x110x185	-	12.8	-	1210	-
4SAm2/16-0.75P	4SA2/16-0.75P	-	-	-	1280x110x185	1130x110x185	14.9	13.8	1070	1210
4SAm2/22-1.1P	4SA2/22-1.1P	-	-	-	1500x110x185	1360x110x185	18.0	16.8	910	1010
4SAm2/28-1.5P	4SA2/28-1.5P	770x125x225	500x125x125	1075x125x125	-	-	M:13.8 B:8.1	M:11 B:8.1	720	1130
4SAm2/38-2.2P	4SA2/38-2.2P	870x125x225	565x125x125	1310x125x125	-	-	M:16.6 B:10.7	M:13.4 B:10.7	620	950
-	4SA2/50-3P	-	645x125x125	1680x125x125	-	-	-	M:18 B:14.1	-	770
-	4SA2/62-4P	-	740x125x125	1980x125x125	-	-	-	M:21 B:17.4	-	650

Model		Dim. (mm)					G.W.(kg)		20"Loading Qty.(pcs)	
Single-phase	Three-phase	Motor(LxWxH)		Body (LxWxH)	Pump(LxWxH)		Single-phase	Three-phase	Single-phase	Three-phase
		Single-phase	Three-phase		Single-phase	Three-phase				
4SAm3/7-0.37P	-	-	-	-	1020x110x185	-	10.8	-	1340	-
4SAm3/9-0.55P	-	-	-	-	1075x110x185	-	12.2	-	1270	-
4SAm3/13-0.75P	4SA3/13-0.75P	-	-	-	1220x110x185	1075x110x185	14.5	13.4	1120	1270
4SAm3/17-1.1P	4SA3/17-1.1P	-	-	-	1360x110x185	1220x110x185	16.9	15.7	1010	1120
4SAm3/21-1.5P	4SA3/21-1.5P	770x125x225	500x125x125	935x125x125	-	-	M:13.8 B:6.7	M:11 B:6.7	770	1240
4SAm3/30-2.2P	4SA3/30-2.2P	870x125x225	565x125x125	1180x125x125	-	-	M:16.6 B:8.6	M:13.4 B:8.6	650	1020
-	4SA3/40-3P	-	645x125x125	1460x125x125	-	-	-	M:18 B:11.6	-	850
-	4SA3/50-4P	-	740x125x125	1735x125x125	-	-	-	M:21 B:14.7	-	710
-	4SA3/60-5.5P	-	780x125x125	2150x125x125	-	-	-	M:24.6 B:17.5	-	610

Model		Dim. (mm)					G.W.(kg)		20"Loading Qty.(pcs)	
Single-phase	Three-phase	Motor(LxWxH)		Body (LxWxH)	Pump(LxWxH)		Single-phase	Three-phase	Single-phase	Three-phase
		Single-phase	Three-phase		Single-phase	Three-phase				
4SAm4/6-0.37P	-	-	-	-	980x110x185	-	11.0	-	1300	-
4SAm4/8-0.55P	-	-	-	-	1075x110x185	-	12.4	-	1230	-
4SAm4/10-0.75P	4SA4/10-0.75P	-	-	-	1130x110x185	930x110x185	14.0	12.8	1120	1350
4SAm4/14-1.1P	4SA4/14-1.1P	-	-	-	1280x110x185	1075x110x185	16.5	15.3	1000	1170
4SAm4/18-1.5P	4SA4/18-1.5P	770x125x225	500x125x125	890x125x125	-	-	M:13.8 B:6.3	M:11 B:6.3	740	1160
4SAm4/24-2.2P	4SA4/24-2.2P	870x125x225	565x125x125	1075x125x125	-	-	M:16.6 B:7.5	M:13.4 B:7.5	630	990
-	4SA4/32-3P	-	645x125x125	1360x125x125	-	-	-	M:18 B:9.7	-	820
-	4SA4/40-4P	-	740x125x125	1550x125x125	-	-	-	M:21 B:12.1	-	720
-	4SA4/50-5.5P	-	780x125x125	1910x125x125	-	-	-	M:24.6 B:15.2	-	600
-	4SA4/60-7.5P	-	920x125x125	2200x125x125	-	-	-	M:31.2 B:18	-	510

Model		Dim. (mm)					G.W.(kg)		20"Loading Qty.(pcs)	
Single-phase	Three-phase	Motor(LxWxH)		Body (LxWxH)	Pump(LxWxH)		Single-phase	Three-phase	Single-phase	Three-phase
		Single-phase	Three-phase		Single-phase	Three-phase				
4SAm6/5-0.37P	-	-	-	-	980x110x185	-	10.8	-	1400	-
4SAm6/6-0.55P	-	-	-	-	1020x110x185	-	11.9	-	1340	-
4SAm6/8-0.75P	4SA6/8-0.75P	-	-	-	1130x110x185	890x110x185	13.6	12.4	1210	1540
4SAm6/11-1.1P	4SA6/11-1.1P	-	-	-	1255x110x185	1020x110x185	16.2	15	1090	1340
4SAm6/14-1.5P	4SA6/14-1.5P	770x125x225	500x125x125	770x125x125	-	-	M:13.8 B:5.6	M:11 B:5.6	830	1410
4SAm6/20-2.2P	4SA6/20-2.2P	870x125x225	565x125x125	1020x125x125	-	-	M:16.6 B:7.2	M:13.4 B:7.2	690	1130
-	4SA6/26-3P	-	645x125x125	1210x125x125	-	-	-	M:18 B:9.1	-	960
-	4SA6/34-4P	-	740x125x125	1500x125x125	-	-	-	M:21 B:11.4	-	780
-	4SA6/42-5.5P	-	780x125x125	1800x125x125	-	-	-	M:24.6 B:13.5	-	690
-	4SA6/50-7.5P	-	920x125x125	2060x125x125	-	-	-	M:31.2 B:16.7	-	600

Model		Dim. (mm)					G.W.(kg)		20"Loading Qty.(pcs)	
Single-phase	Three-phase	Motor(LxWxH)		Body (LxWxH)	Pump(LxWxH)		Single-phase	Three-phase	Single-phase	Three-phase
		Single-phase	Three-phase		Single-phase	Three-phase				
4SAm8/5-0.55P	-	-	-	-	1020x110x185	-	11.8	-	1340	-
4SAm8/7-0.75P	4SA8/7-0.75P	-	-	-	1130x110x185	980x110x185	13.5	12.4	1210	1400
4SAm8/9-1.1P	4SA8/9-1.1P	-	-	-	1255x110x185	1130x110x185	15.8	14.6	1090	1210
4SAm8/12-1.5P	4SA8/12-1.5P	770x125x225	500x125x125	810x125x125	-	-	M:13.8 B:5.3	M:11 B:5.3	810	1360
4SAm8/18-2.2P	4SA8/18-2.2P	870x125x225	565x125x125	1075x125x125	-	-	M:16.6 B:7.3	M:13.4 B:7.3	670	1090
-	4SA8/24-3P	-	645x125x125	1310x125x125	-	-	-	M:18 B:9.4	-	910
-	4SA8/30-4P	-	740x125x125	1550x125x125	-	-	-	M:21 B:11.1	-	780
-	4SA8/38-5.5P	-	780x125x125	1910x125x125	-	-	-	M:24.6 B:14	-	660
-	4SA8/46-7.5P	-	920x125x125	2200x125x125	-	-	-	M:31.2 B:17.5	-	570

Model		Dim. (mm)					G.W.(kg)		20"Loading Qty.(pcs)	
Single-phase	Three-phase	Motor(LxWxH)		Body (LxWxH)	Pump(LxWxH)		Single-phase	Three-phase	Single-phase	Three-phase
		Single-phase	Three-phase		Single-phase	Three-phase				
4SAm10/5-0.75P	4SA10/5-0.75P	-	-	-	1075x110x185	955x110x185	12.9	11.8	1270	1440
4SAm10/7-1.1P	4SA10/7-1.1P	-	-	-	1180x110x185	1020x110x185	15.3	14.1	1060	1340
4SAm10/10-1.5P	4SA10/10-1.5P	770x125x225	500x125x125	730x125x125	-	-	M:13.8 B:4.9	M:11 B:4.9	840	1450
4SAm10/14-2.2P	4SA10/14-2.2P	870x125x225	565x125x125	890x125x125	-	-	M:16.6 B:6.1	M:13.4 B:6.1	720	1230
-	4SA10/18-3P	-	645x125x125	1075x125x125	-	-	-	M:18 B:7.4	-	1040
-	4SA10/22-4P	-	740x125x125	1210x125x125	-	-	-	M:21 B:8.7	-	910
-	4SA10/28-5.5P	-	780x125x125	1460x125x125	-	-	-	M:24.6 B:10.7	-	800
-	4SA10/34-7.5P	-	920x125x125	1680x125x125	-	-	-	M:31.2 B:12.7	-	680

Model		Dim. (mm)					G.W.(kg)		20"Loading Qty.(pcs)	
Single-phase	Three-phase	Motor(LxWxH)		Body (LxWxH)	Pump(LxWxH)		Single-phase	Three-phase	Single-phase	Three-phase
		Single-phase	Three-phase		Single-phase	Three-phase				
4SAm12/4-0.75P	4SA12/4-0.75P	-	-	-	1100x110x185	890x110x185	13.7	12.5	1240	1530
4SAm12/6-1.1P	4SA12/6-1.1P	-	-	-	1255x110x185	1020x110x185	16.2	14.9	1080	1330
4SAm12/8-1.5P	4SA12/8-1.5P	770x125x225	500x125x125	730x125x125	-	-	M:13.8 B:5.4	M:11 B:5.4	830	1440
4SAm12/12-2.2P	4SA12/12-2.2P	870x125x225	565x125x125	980x125x125	-	-	M:16.6 B:7.4	M:13.4 B:7.4	690	1140
-	4SA12/16-3P	-	645x125x125	1180x125x125	-	-	-	M:18 B:9.3	-	970
-	4SA12/20-4P	-	740x125x125	1415x125x125	-	-	-	M:21 B:11.7	-	820
-	4SA12/26-5.5P	-	780x125x125	1735x125x125	-	-	-	M:24.6 B:14.1	-	700
-	4SA12/32-7.5P	-	920x125x125	2060x125x125	-	-	-	M:31.2 B:16.8	-	590

Model		Dim. (mm)					G.W.(kg)		20"Loading Qty.(pcs)	
Single-phase	Three-phase	Motor(LxWxH)		Body (LxWxH)	Pump(LxWxH)		Single-phase	Three-phase	Single-phase	Three-phase
		Single-phase	Three-phase		Single-phase	Three-phase				
4SAm16/4-1.1P	4SA16/4-1.1P	-	-	-	1255x110x185	1130x110x185	16.1	15	1090	1210
4SAm16/6-1.5P	4SA16/6-1.5P	770x125x225	500x125x125	810x125x125	-	-	M:13.8 B:5.8	M:11 B:5.8	810	1360
4SAm16/9-2.2P	4SA16/9-2.2P	870x125x225	565x125x125	1020x125x125	-	-	M:16.6 B:7.4	M:13.4 B:7.4	690	1130
-	4SA16/12-3P	-	645x125x125	1255x125x125	-	-	-	M:18 B:9.1	-	940
-	4SA16/16-4P	-	740x125x125	1550x125x125	-	-	-	M:21 B:12.1	-	780
-	4SA16/20-5.5P	-	780x125x125	1855x125x125	-	-	-	M:24.6 B:14.3	-	680
-	4SA16/24-7.5P	-	920x125x125	2150x125x125	-	-	-	M:31.2 B:17.1	-	580

