

Performance Curve

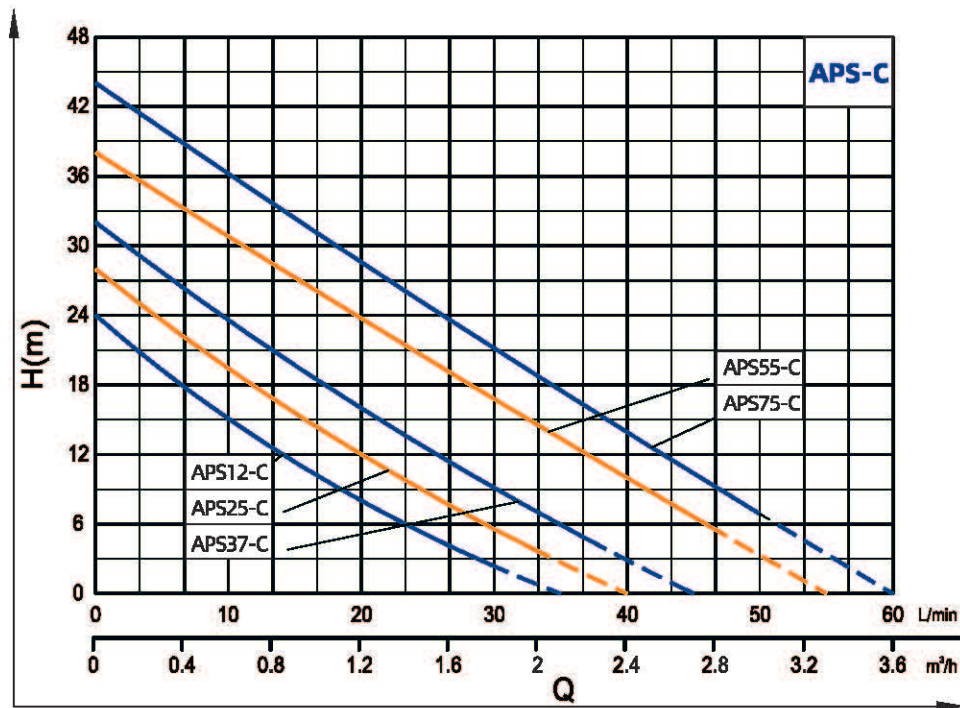

Model	Power		Max. Flow (m³/h)	Max. Head (m)	Head Range (m)	Max. Suction (m)
	kW	HP				
APS12-C	0.125	0.17	2.1	24	20~0	6
APS25-C	0.25	0.34	2.4	28	24~0	6
APS37-C	0.37	0.5	2.7	32	28~0	6
APS55-C	0.55	0.75	3.3	38	34~0	6
APS75-C	0.75	1	3.6	44	40~0	6

NOTE: 0.3m short-term without plug

Components & Materials

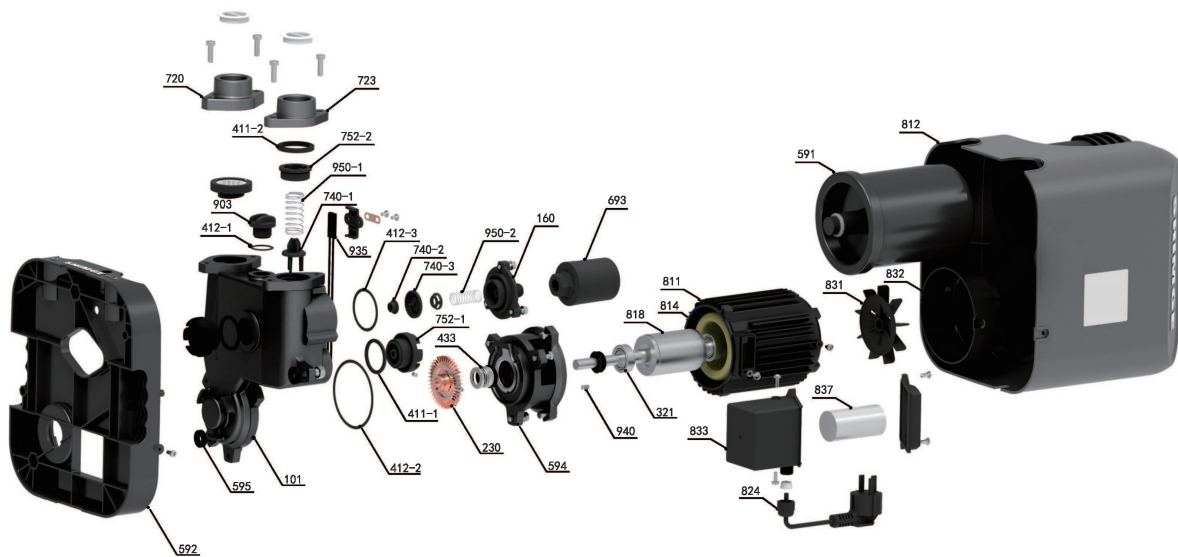

No.	Part name	No.	Part name	No.	Part name
742-1	Valve sleeve	903	Vent cock	101	Pump body
740-2	Diaphragm seat	742-2	Check valve with filter	950-2	Small spring
230	Impeller	740-3	Diaphragm	740-1	Flow stabilizing valve
752-1	Check valve seat	412-3	O-ring	433	Mechanical seal
412-2	O-ring	837	Running capacitor	594	Connector body
824	Cable (domestic)	833	Junction box	935	External thermal protector
723	Inlet pipe	818	Rotor	832	Fan cover
940	Ordinary flat key	812	Outer housing	693	Pressure switch
412-1	O-ring	720	Outlet pipe	591	Pressure tank
752-2	Flow stabilizer Locating sleeve	410	Rubber washer	321	Deep groove ball bearing
950-1	Large spring	160	Flow stabilizer cover	831	Fan\QB60
411	Rubber washer	811	Casing	814	Stator core with winding
592	Base	595	Rubber ring		

Model	APS12-C	APS25-C	APS37-C	APS55-C	APS75-C
Capacitor	10μF\450V	10μF\450V	12μF\450V	12μF\450V	18μF\450V
End cap Bearing	6201-2RZ	6201-2RZ	6201-2RZ	6202-2RZ	6202-2RZ
Connection Part Bearing	6201-2RZ	6201-2RZ	6201-2RZ	6202-2RZ	6202-2RZ
Motor Shaft	45#+304#	45#+304#	45#+304#	45#+304#	45#+304#
Mechanical Seal	108-12/21&B:A(RC)	108-12/21&B:A(RC)	108-12/21&B:A(RC)	108-12/21&B:A(RC)	108-12/21&B:A(RC)
Motor Case	Aluminum	Aluminum	Aluminum	Aluminum	Aluminum
Coupling	cast iron	cast iron	cast iron	cast iron	cast iron
Pump Body	cast iron	cast iron	cast iron	cast iron	cast iron
Impeller	copper	copper	copper	copper	copper

Dimensions & Weight

Model	DN1	DN2	Dim.(mm)										N.W. (kg)
	Inch		A	B	C	E	F	L	H1	H2	H3	S	
APS12-C	1	1	85	279	120	95	50	241	40	50	269	125	10.2
APS25-C	1	1	85	279	120	95	50	241	40	50	269	125	10.9
APS37-C	1	1	85	279	120	95	50	241	40	50	269	125	11.2
APS55-C	1	1	85	305	144	105	60	270	45	56.5	295	155	14
APS75-C	1	1	85	305	144	105	60	270	45	56.5	295	155	14.9

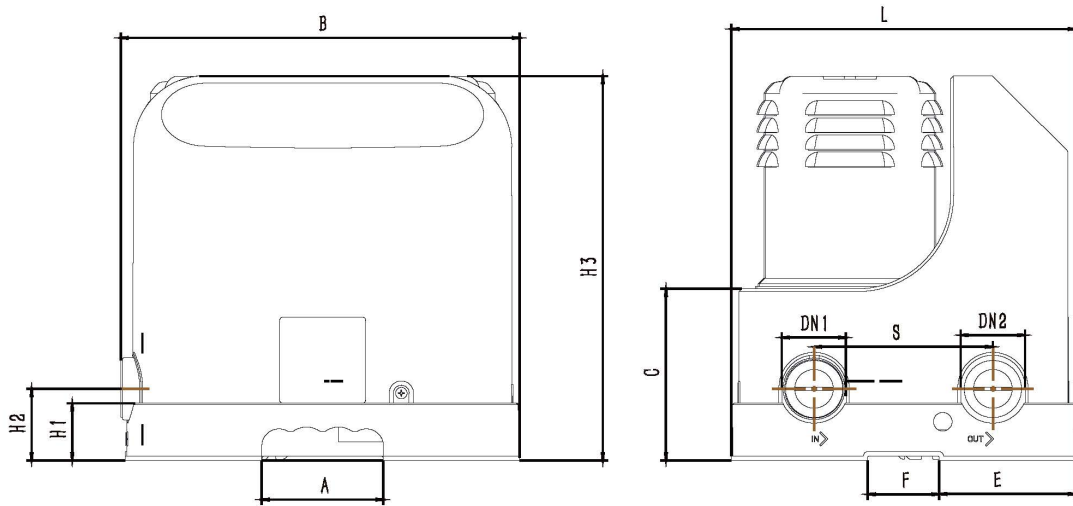

Packing Size & Weight

Model	Dim.(LxWxH) mm	N.W. (kg)	G.W. (kg)	20'Loading Qty. (pcs)
APS12-C	330x300x320	10.2	10.9	931
APS25-C	330x300x320	10.9	11.7	931
APS37-C	330x300x320	11.2	12.2	931
APS55-C	370x340x355	14.0	15.0	918
APS75-C	370x340x355	14.9	15.9	918

