

Performance Curve

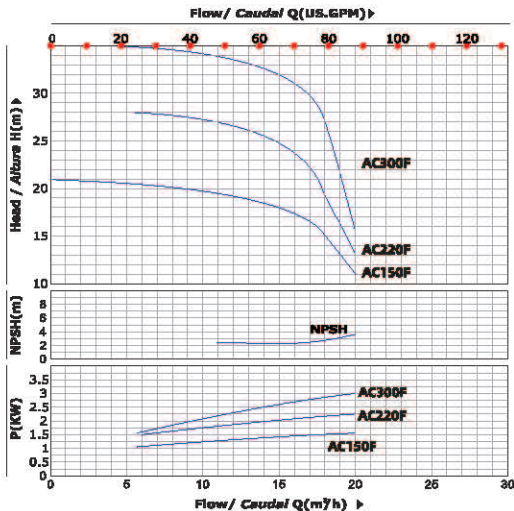

50x32

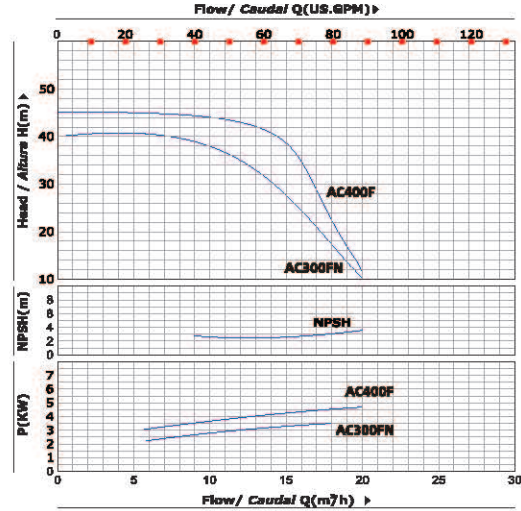

50x32

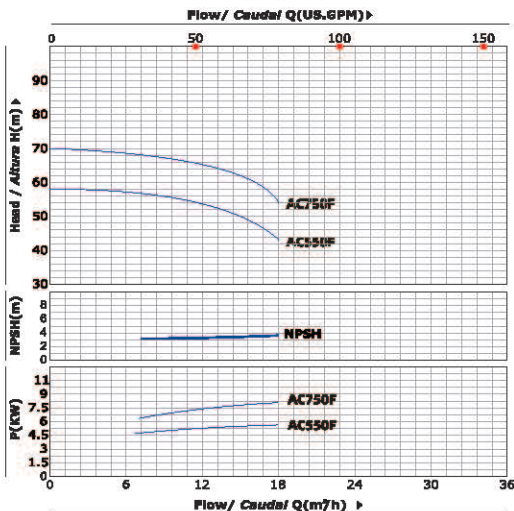

50x32

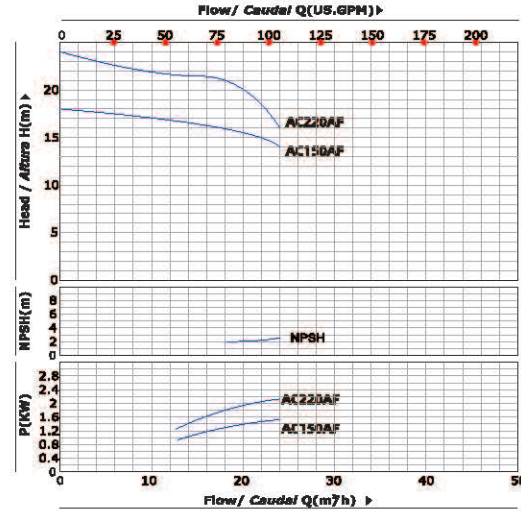

65x40

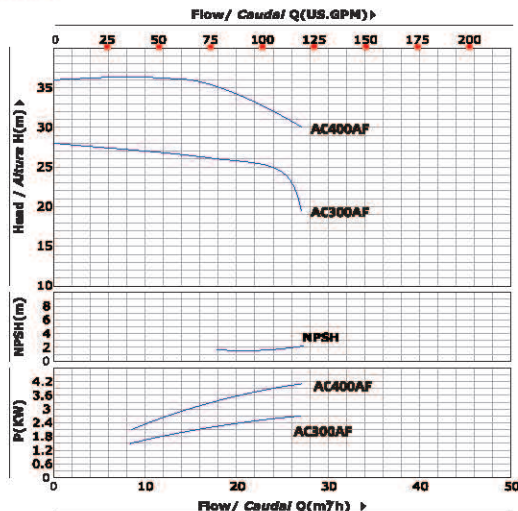

65x40

Performance Curve

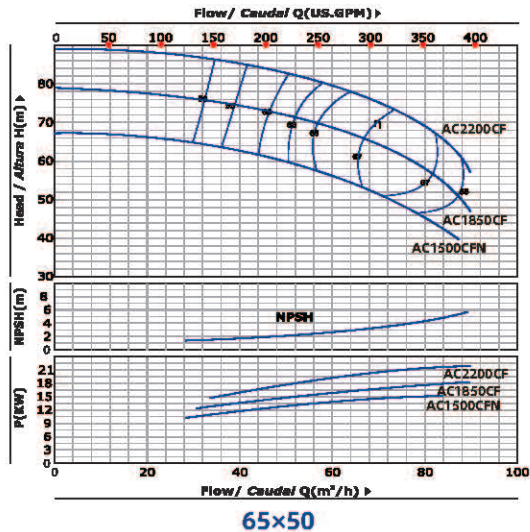
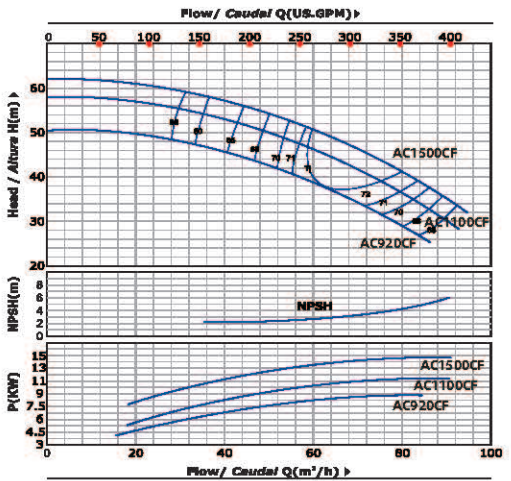
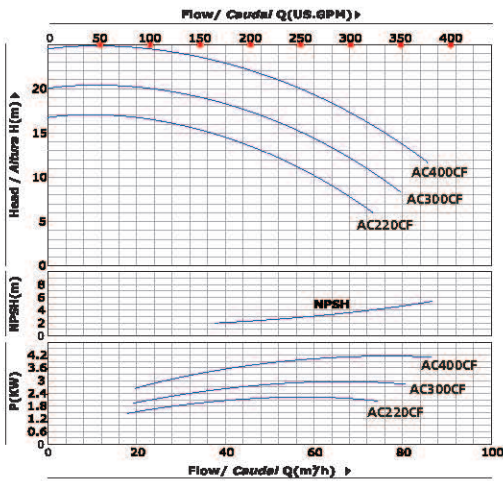
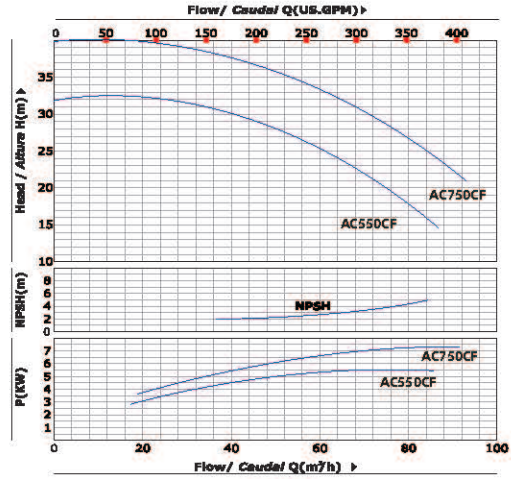
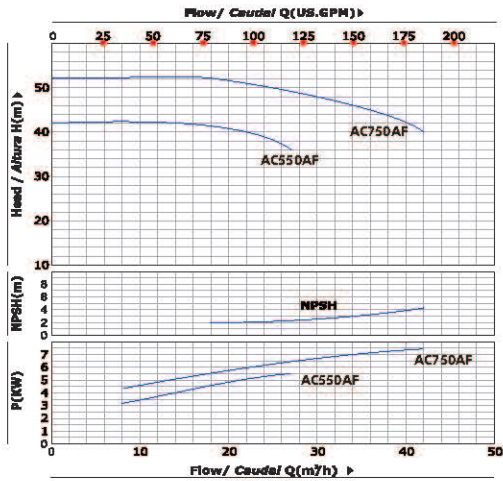

Performance Curve

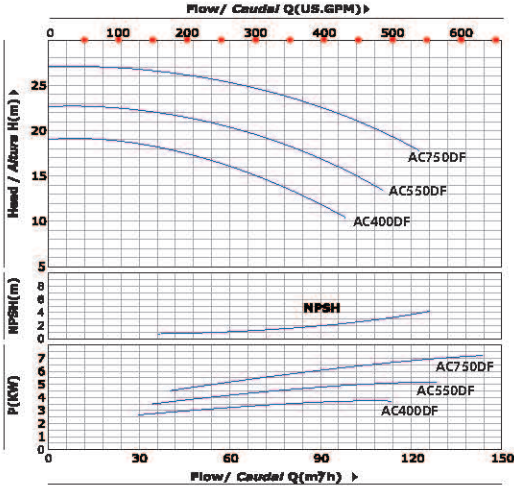

80x65

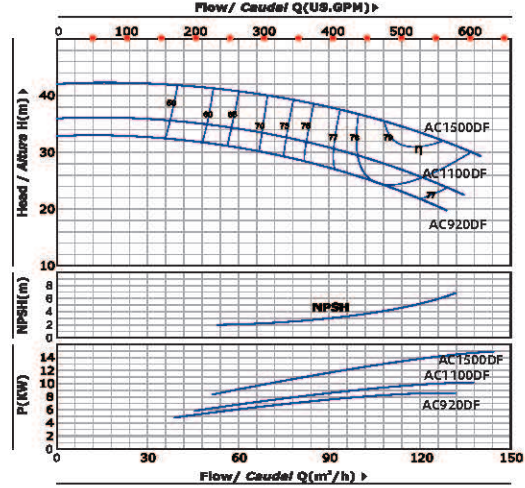

80x65

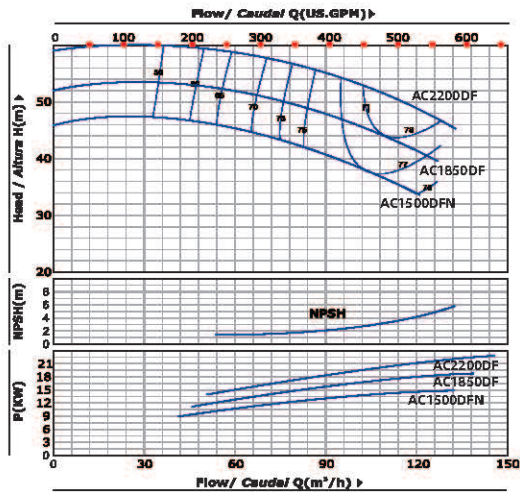

80x65

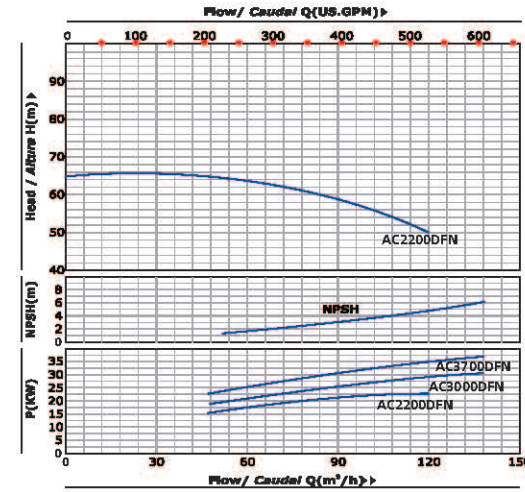

80x65

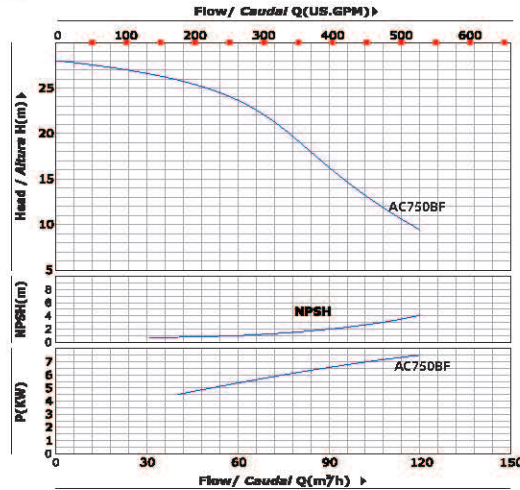

100x80

Performance Curve

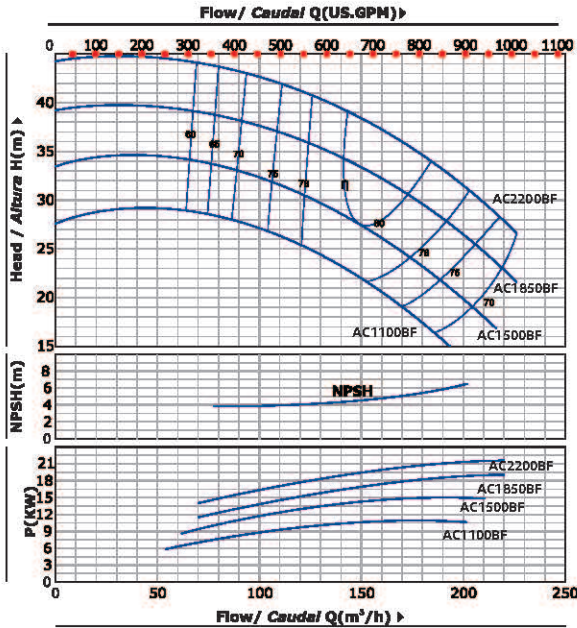

100x80

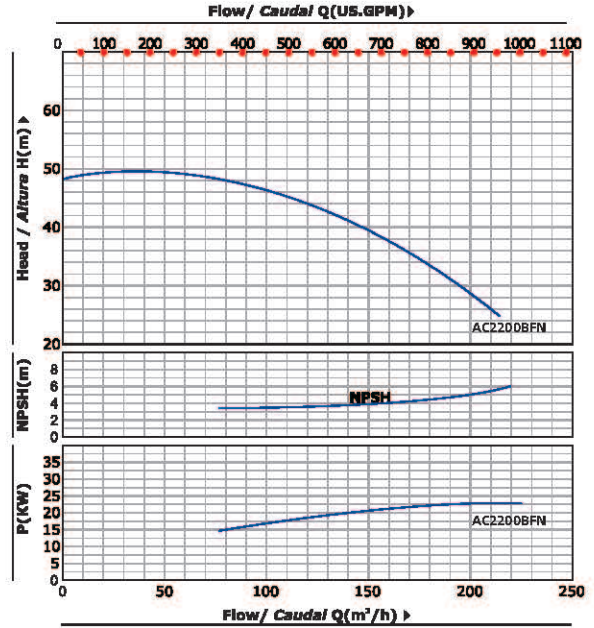

100x80

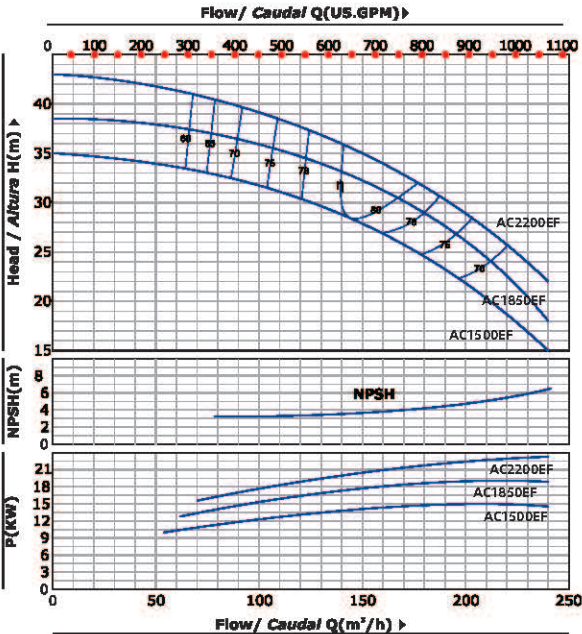

125x100

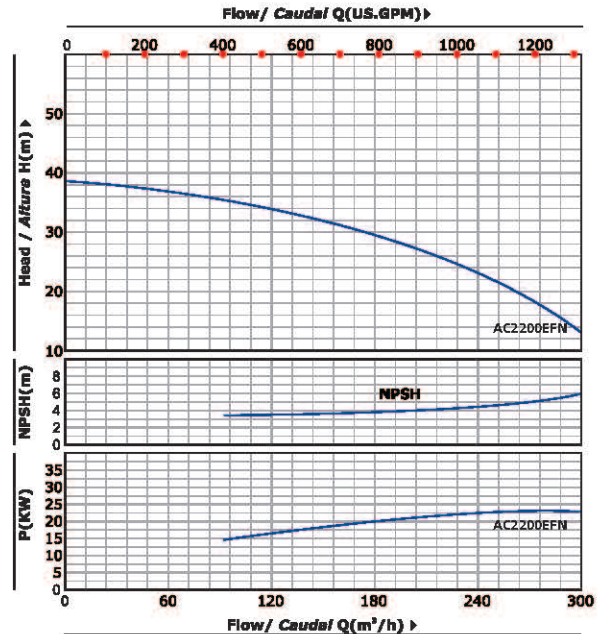

125x100

Model	power		Rated point		Caliber	l/min	0	100	150	250	300	400	450	600	700	800	900	1200	1400	1500	1800	2000	2300	3000		
	kW	HP	m³/h	m			mm	m³/h	0	6	9	15	18	24	27	36	42	48	54	72	84	90	108	120	138	180
	AC150F	1.5	2	15	18	50x32	H (m)	21		20	18	16.5														
AC220F	2.2	3	15	25	50x32	28				27.5	25	19														
AC300F	3	4	15	32	50x32	35				34.5	32	27														
AC300FN	3	4	13	30	50x32	40				38	29	20														
AC400F	4	5.5	15	38	50x32	45				45	38	35														
AC550F	5.5	7.5	15	50	50x32	58				56	50	43														
AC750F	7.5	10	15	62	50x32	70				67	62	54														
AC150AF	1.5	2	20	15	65x40	18				17	16.5	16	14													
AC220AF	2.2	3	20	20	65x40	24				22	21.5	21	16													
AC300AF	3	4	25	24	65x40	28				27	26.5	26	25	19.5												
AC400AF	4	5.5	25	32	65x40	36					36	35	32.5	30												
AC550AF	5.5	7.5	25	38	65x40	42					42	41	38.5	36	24											
AC750AF	7.5	10	25	48	65x40	52					52	52	49	48	46	40										
AC220CF	2.2	3	50	12	65x50	17									15.4	14	12.8	11.5	6.5							
AC300CF	3	4	55	15	65x50	20									18.8	18	17	15.6	11							
AC400CF	4	5.5	60	18	65x50	24									23.1	23	21.5	20.3	15.8	11.8						
AC550CF	5.5	7.5	50	27	65x50	32									30.6	30	28	26.6	20.5	14.8						
AC750CF	7.5	10	60	28	65x50	40									38	36	34	30	26	21						
AC920CF	9.2	12.5	48	43	65x50	50.5									46.8	45	43	40.9	32.5	26.7						
AC1100CF	11	15	60	45	65x50	57.5									53.5	52	50	47.5	40	34	29					
AC1500CF	15	20	65	50	65x50	62									58	56.5	54.5	52	44.5	39	35.5					
AC1500CFN	15	20	50	60	65x50	68.5									64	63	61.5	59	50	41						
AC1850CF	18.5	25	55	70	65x50	79									75.8	74.8	74	71.5	63.5	55.5	47					
AC2200CF	22	30	60	75	65x50	89.5									86	85.3	84	81.5	73.5	65.5	57					
AC400DF	4	5.5	62	16	80x65	19											17.3	16.8	14.5	13	11.8					
AC550DF	5.5	7.5	74	19	80x65	23											21.3	20.9	19	17.5	16.7	13.7				
AC750DF	7.5	10	85	20	80x65	27											26	25	23	20	19	18	16			
AC920DF	9.2	12.5	72	30	80x65	33												31.5	30	28	27.1	24	21.5			
AC1100DF	11	15	74	33	80x65	36												34.5	33	31.5	30.8	28	25.5			
AC1500DF	15	20	85	38	80x65	42												41	40	38.5	37.8	35	33	29.5		
AC1500DFN	15	20	62	44	80x65	45												45.5	43	41	40.2	36.5	34			
AC1850DF	18.5	25	74	50	80x65	52												52.3	51	49	48.2	44.5	42			
AC2200DF	22	30	85	54	80x65	59												59.5	58	56	55	52	49.5	44.5		
AC2200DFN	22	30	84	60	80x65	64.8											64.7	62	60	58.5	53	50				
AC750BF	7.5	10	85	18	100x80	28										25	24.5	22	19	16.5	10.5					

Model	power		Rated point		Caliber	l/min	0	1000	1500	2000	2400	3000	3333	3500	3666	4000	4666	5000	6000	6666	8333	10000	13333	16666		
	kW	HP	m³/h	m			mm	m³/h	0	60	90	120	144	180	200	210	220	240	280	300	360	400	500	600	800	1000
	AC1100BF	11	15	130	22.5	100x80	H (m)	27	27	27.3	24.5	21.1	16													
AC1500BF	15	20	145	27	100x80	32.8		32.6	32.5	30	27	22.1	18.5	16.7												
AC1850BF	18.5	25	160	31	100x80	39		38.5	38	35	33.6	28.8	25.3	23.5												
AC2200BF	22	30	160	35	100x80	44		43.5	43	41.7	38.6	33.8	30.3	28.5												
AC2200BF	22	30	130	42	100x80	48		47.7	47.5	43.5	39.2	32.5	27.2	24.5												
AC1500EF	15	20	180	24.5	125x100	35		33.5	32.5	30	27.8	24.5	21.5	20	18.3	15										
AC1850EF	18.5	25	180	29	125x100	38.5		37.5	36.5	34.3	32.2	29	25.7	24	22	18										
AC2200EF	22	30	180	31.5	125x100	43		41	40	37.6	35.2	31.5	28.5	27	25.3	22										
AC2200EFN	22	30	150	32	125x100	38.5		36.7	35.7	33.8	31.7	28.5	26.8	26	25	22.9	16.3	13								

Components & Materials

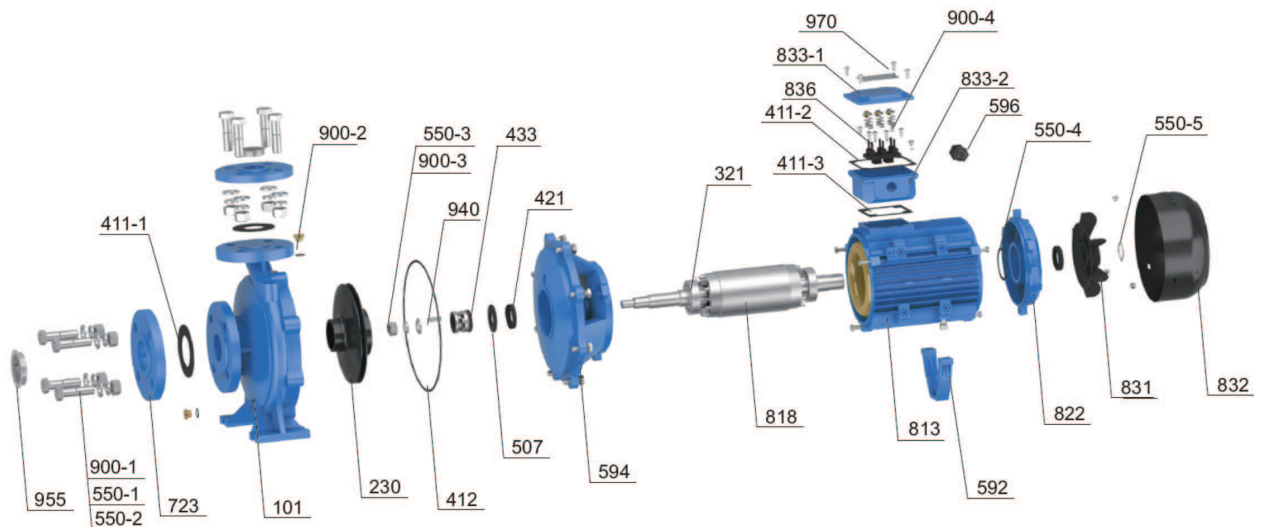

No.	Component	No.	Component	No.	Component
101	Pump body	550-4	Wave spring	836	Wiring terminal
230	Pump cover	550-5	Circlip for shaft	900-1	Hexagon head bolt
321	Impeller (I)	592	Foot	900-2	Vent cock
411-1	Impeller (II)	594	Connector	900-3	Flat washer
411-2	Deep groove ball bearing	596	Cable lock	900-4	Cross recessed pan head screw
411-3	Seal (flat)	723	Flange	940	Ordinary flat key
412	Rubber gasket	813	Stator	955	Dust cover
421	Rubber gasket	818	Rotor	970	Nameplate
433	Machinery Seal	822	Rear end cover		
507	Water retaining ring	831	Fan		
550-1	Spring washer	832	Fan cover		
550-2	Type I hexagon nut	833-1	Junction box cover		
550-3	Type I hexagon nut	833-2	Junction box		

Components & Materials

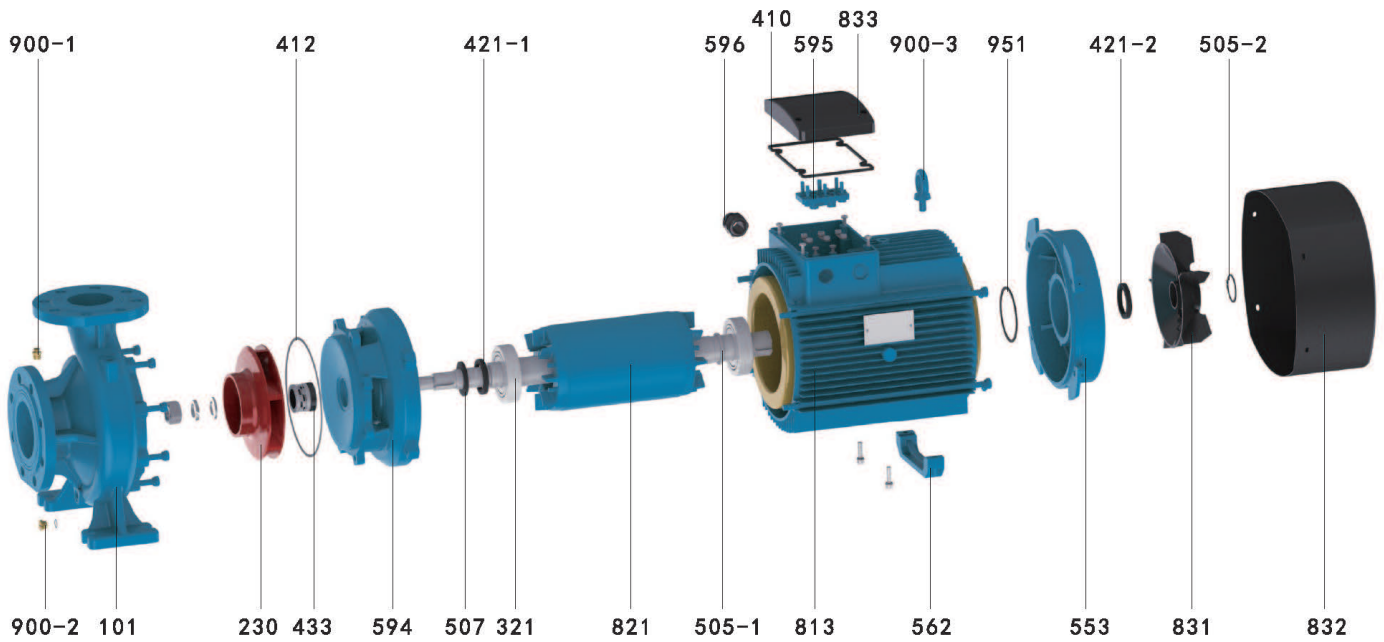

No.	Component	No.	Component	No.	Component	No.	Component	No.	Component
101	Pump body	421-1	Framework oil seal	507	Washer	596	Cable lock head	833	Junction box
230	Impeller	421-2	Framework oil seal	553	End cap	813	Stator	951	Wave spring
321	Bearing	433	Mechanical seal	562	Footing	821	Rotor	900-1	Vent cock
410	Rubber blanket	505-1	Check ring	594	Coupling	831	Fan	900-2	Vent cock
412	O-ring	505-2	Check ring	595	Terminal	832	Fan housing	900-3	Lifting bolt

Power (kW)	1.5	2.2	3	4	5.5	7.5
End-cover bearing	6204-2RS/C3Z2	6204-2RS/C3Z2	6205-2RS/C3Z2	6206-2RS/C3Z2	6206-2RS/C3Z2	6208-2RS/C3Z2
Coupling bearing	6205-2RS/C3Z2	6205-2RS/C3Z2	6205-2RS/C3Z2	6206-2RS/C3Z2	6206-2RS/C3Z2	6208-2RS/C3Z2
Motor Shaft	Steel 45#+304					
Mechanical Seal	701-20/29 S:K(P) Stationary seal ring ø35			701-25/31 S:K(P) Stationary seal ring ø40		701-28/32 S:K(P) Stationary seal ring ø40
	A:Graphite B:Alumina ceramic S:RBSC P:NBR					
Motor Case	Aluminum					
Coupling	Cast Iron					
Pump body	Cast Iron					
Impeller	Cast Iron					
Pump Cover	Cast Iron					

Dimensions & Weight

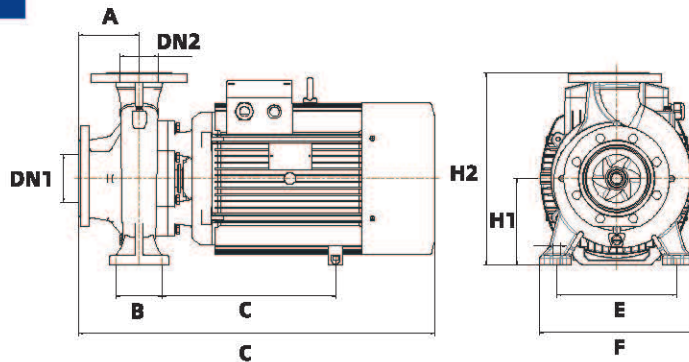

Model	DN1	DN2	A	B	C	D	E	F	S	H1	H2
AC150F	50	32	80	70	202	411	190	240	14	132	292
AC220F	50	32	80	70	210	445	190	240	14	132	292
AC300F	50	32	80	70	226	451	190	240	14	132	292
AC300FN	50	32	80	70	228	453	190	240	14	160	340
AC400F	50	32	80	70	219	480	190	240	14	160	340
AC550F	50	32	80	70	229	500	190	240	14	160	340
AC750F	50	32	80	70	246	550	190	240	14	160	340
AC150AF	65	40	80	70	202	411	160	210	14	112	252
AC220AF	65	40	80	70	210	444.5	160	210	14	112	252
AC300AF	65	40	80	70	231	456	175	210	14	126	286
AC400AF	65	40	80	70	221	481.5	175	210	14	126	286
AC550AF	65	40	100	70	226	517	215	265	14	260	340
AC750AF	65	40	100	70	243	567	215	265	14	260	340
AC220CF	65	50	93.5	60	241	471	168	232	14	132	305
AC300CF	65	50	93.5	60	257	477	168	232	14	132	305
AC400CF	65	50	93.5	60	250	505	168	232	14	132	305
AC550CF	65	50	100	70	221	510	215	273	14	160	349
AC750CF	65	50	100	70	240	564	215	273	14	160	349
AC920CF	65	50	100	95	267.5	585	250	320	14	180	385
AC1100CF	65	50	100	95	305.5	623	250	320	14	180	385
AC1500CF	65	50	100	95	307.5	660	250	320	14	180	385
AC1500CFN	65	50	100	95	307.5	660	250	320	14	180	410
AC1850CF	65	50	100	95	307.5	660	250	320	14	180	410
AC2200CF	65	50	100	95	351.5	704	250	320	14	180	410
AC400DF	65	50	108	95	214.5	515	210	280	14	160	349
AC550DF	65	50	108	95	222.5	536	210	280	14	160	349
AC750DF	80	65	110	95	237.5	584	210	280	14	160	349
AC920DF	80	65	108	95	282.5	608	215	280	14	180	370
AC1100DF	80	65	108	95	320.5	646	215	280	14	180	370
AC1500DF	80	65	108	95	322.5	683	215	316	14	180	390
AC1500DFN	80	65	108	95	328.5	689	250	320	14	180	423
AC1850DF	80	65	108	95	328.5	689	250	320	14	180	423
AC2200DF	80	65	108	95	372.5	733	250	320	14	180	423
AC2200DFN	80	65	110	95	375.5	738	250	320	14	180	415
AC750BF	100	80	100	70	248	572	215	265	14	160	340
AC1100BF	100	80	125	95	320.5	663	250	326	14	180	420
AC1500BF	100	80	125	95	322.5	700	250	326	14	180	420
AC1850BF	100	80	125	95	322.5	700	250	326	14	180	420
AC2200BF	100	80	125	95	366.5	744	250	326	14	180	420
AC2200BF	100	80	125	95	361.5	739	250	320	14	180	400
AC1500EF	125	100	125	95	323.5	701	250	336	14	180	433
AC1850EF	125	100	125	95	323.5	701	250	336	14	180	433
AC2200EF	125	100	125	95	367.5	745	250	336	14	180	433
AC2200EFN	125	100	125	95	367.5	745	250	336	14	180	433

Packing Size & Weight

Model	Net weight(kg)	Gross weight(kg)	Packaging box dimensions LxWxH(mm)
AC150F	32	35	490x285x355
AC220F	37	40	520x385x355
AC300F	40	43	565x275x390
AC300FN	43	47	560x325x440
AC400F	52	57	590x325x440
AC550F	63.5	68.5	610x325x440
AC750F	74	79	660x325x440
AC150AF	31	34	490x255x315
AC220AF	37	40	520x255x315
AC300AF	43	48	565x275x390
AC400AF	51	56	590x275x390
AC550AF	61	66	630x300x440
AC750AF	73.5	83.5	680x300x440
AC220CF	40	43	590x275x390
AC300CF	44	48	590x275x390
AC400CF	48	53	610x325x440
AC550CF	59	64	630x320x505
AC750CF	82	90	680x320x505
AC920CF	90	98	685x320x505
AC1100CF	98	110	740x360x540
AC1500CF	124	136	740x360x540
AC1500CFN	128	140	740x360x540
AC1850CF	141	153	740x360x540
AC2200CF	155	167	815x370x525
AC400DF	59	64	630x320x505
AC550DF	65	70	630x320x505
AC750DF	88	96	685x320x505
AC920DF	93	105	685x320x505
AC1100DF	102	114	740x360x540
AC1500DF	129	141	740x360x540
AC1500DFN	128	140	815x370x525
AC1850DF	142	154	815x370x525
AC2200DF	155	167	815x370x525
AC2200DFN	158	170	815x370x525
AC750BF	75.5	84.5	700x300x450
AC1100BF	107	119	740x360x540
AC1500BF	134	146	815x370x555
AC1850BF	148	160	815x370x555
AC2200BF	161	173	815x370x555
AC2200BF	158	170	815x370x555
AC1500EF	140	152	815x370x555
AC1850EF	153	165	815x370x555
AC2200EF	167	179	815x370x525
AC2200EFN	167	179	815x370x525

